

3/S1
v 2.6 (hr)

SAPNICE

SAP-F, SAP-Z



SADRŽAJ

Sapnice, tip SAP-Z.....	193
Sapnice, tip SAP-F.....	194
Izborni dijagrami.....	196
Motorni pogon.....	202

Oznake:

V [m ³ /h]	- protok zraka	H_{uk} [m]	- Ukupna visina ugradnje sapnice
y [m]	- otklon mlaza	α [°]	- Kut namještanja sapnice i istrujavanja mlaza
A [m]	- horizontalna udaljenost od sapnice do točke sudara dvaju mlazova	v_L [m/s]	- Srednja brzina mlaza u točki sudara dvaju mlazova
B [m]	- međusobni razmak između sapnica ugrađenih u nizu	v_{H1} [m/s]	- Srednja brzina mlaza u zoni boravka
L [m]	- domet izotermnog mlaza	Δt_{H1} [K]	- temperaturna razlika između temperature mlaza t_m i temperature prostorije t_L
L_{max} [m/s]	- maksimalni domet izotermnog vertikalnog mlaza	Δt_L [K]	- temperaturna razlika između temperature mlaza na udaljenosti L i prostorije
H_1 [m]	- vertikalna udaljenost od točke sudara dvaju mlazova do zone boravka		
H_2 [m]	- vertikalna udaljenost od točke sudara dvaju izotermnih mlazova do položaja ugradnje		

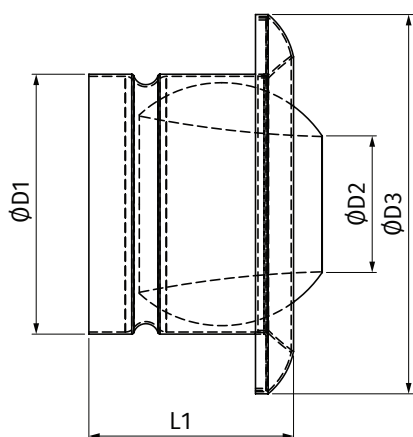
SAP - Z

- Sapnice za ubacivanje zraka u prostore u kojima se zahtjeva velik domet mlaza i niska šumnost.
- Zglobne sapnice, izrađene od aluminija i standardno plastificirane u RAL 9010. Na zahtjev kupca moguće je plastificiranje u druge boje, RAL...
- Mogućnost podešavanja kuta istrujavanja ($\pm 30^\circ$) ručno ili putem motornog pogona

Opcije

- RAL...
- Motorni pogon

Dimenzije	Ø D1 [mm]	Ø D2 [mm]	Ø D3 [mm]	L1 [mm]
100	101	48	148	79
125	126	60	170	89
160	159	76	200	118
200	203	96	265	138
250	248	127	309	178
315	317	180	378	195
400	396	220	466	214

Tablica za brzi odabir SAP-Z

	ØD2	V (m³/h)	v _{ef} (m/s)	L (m)	L _{WA} (dB(A))	v _L (m/s)	V (m³/h)	v _{ef} (m/s)	L (m)	L _{WA} (dB(A))	v _L (m/s)	V (m³/h)	v _{ef} (m/s)	L (m)	L _{WA} (dB(A))	v _L (m/s)	
	100	50	47	6,62	<20	0,25 m/s	94	13,24	20 m	31	0,25 m/s	140	19,86	30 m	42	0,25 m/s	
	125	64	61	5,28			<20	122		10,57		27	180		15,54		37
	160	82	83	4,36			<20	166		8,71		<20	248		13,07		32
	200	108	104	3,17			<20	220		6,66		<20	306		9,28		25
	250	136	133	2,55			<20	274		5,23		<20	382		7,30		23
	315	174	180	2,10			<20	353		4,12		<20	540		6,31		21
	400	230	234	1,56			<20	464		3,10		<20	702		4,69		<20

	ØD2	V (m³/h)	v _{ef} (m/s)	L (m)	L _{WA} (dB(A))	v _L (m/s)	V (m³/h)	v _{ef} (m/s)	L (m)	L _{WA} (dB(A))	v _L (m/s)	V (m³/h)	v _{ef} (m/s)	L (m)	L _{WA} (dB(A))	v _L (m/s)
	100	50	94	13,24	31	0,5 m/s	187	26,48	20 m	51	0,5 m/s	187	26,48	30 m	51	0,5 m/s
	125	64	122	10,57	27		245	21,14		46		306	26,42		51	
	160	82	166	8,71	<20		331	17,42		39		497	26,13		50	
	200	108	220	6,66	<20		436	13,21		36		655	19,87		47	
	250	136	274	5,23	<20		547	10,46		32		824	15,76		43	
	315	174	353	4,12	<20		702	8,20		27		1055	12,32		39	
	400	230	464	3,10	<20		929	6,21		27		1393	9,31		37	

SAP - F

- Fiksne sapnice za ubacivanje zraka u prostore u kojima se zahtijeva velik domet mlaza i niska šumnost.
- Fiksne sapnice, izrađene od aluminija i standardno plastificirane u RAL 9010. Na zahtjev kupca moguće je plastificiranje u druge boje, RAL....

Opcije

- RAL...

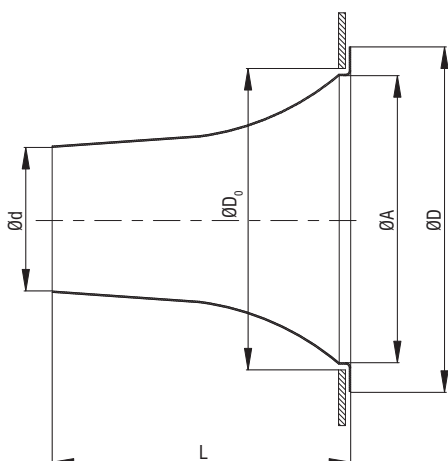

SAP-F	Ød [mm]	ØD [mm]	ØD ₀ [mm]	ØA [mm]	L [mm]	A _{ef} [m ²]
	50	130	105	100	105	0,002
	75	180	156	150	157	0,004
	100	240	210	200	210	0,007
	125	330	295	285	240	0,012
	150	350	310	300	290	0,017
	175	350	310	300	190	0,024
	200	510	460	450	380	0,031

Tablica za brzi odabir SAP-F

	V (m ³ /h)	v _{ef} (m/s)	L (m)	L _{WA} (dB(A))	v _L (m/s)	V (m ³ /h)	v _{ef} (m/s)	L (m)	L _{WA} (dB(A))	v _L (m/s)	V (m ³ /h)	v _{ef} (m/s)	L (m)	L _{WA} (dB(A))	v _L (m/s)
50	47	6,65	10 m	<20	0,25 m/s	94	13,30	20 m	31	0,25 m/s	140	19,81	30 m	42	0,25 m/s
75	76	4,78		<20		150	9,43		24		223	14,02		35	
100	97	3,43		<20		195	6,90		<20		324	11,46		28	
125	130	2,94		<20		263	5,95		<20		367	8,31		24	
150	137	2,15		<20		288	4,53		<20		430	6,76		22	
175	170	1,96		<20		355	4,10		<20		558	6,44		20	
200	205	1,81		<20		432	3,82		<20		630	5,57		20	

	V (m ³ /h)	v _{ef} (m/s)	L (m)	L _{WA} (dB(A))	v _L (m/s)	V (m ³ /h)	v _{ef} (m/s)	L (m)	L _{WA} (dB(A))	v _L (m/s)	V (m ³ /h)	v _{ef} (m/s)	L (m)	L _{WA} (dB(A))	v _L (m/s)
50	94	13,30	10 m	31	0,5 m/s	187	26,46	20 m	51	0,5 m/s	187	26,46	30 m	51	0,5 m/s
75	155	9,75		25		306	19,24		42		418	26,28		50	
100	225	7,96		<20		432	15,28		37		612	21,65		49	
125	270	6,11		<20		486	11,00		34		756	17,11		45	
150	295	4,64		<20		594	9,34		30		900	14,15		42	
175	360	4,16		<20		706	8,15		27		1062	12,26		39	
200	432	3,82		<20		468	4,14		27		1152	10,19		38	

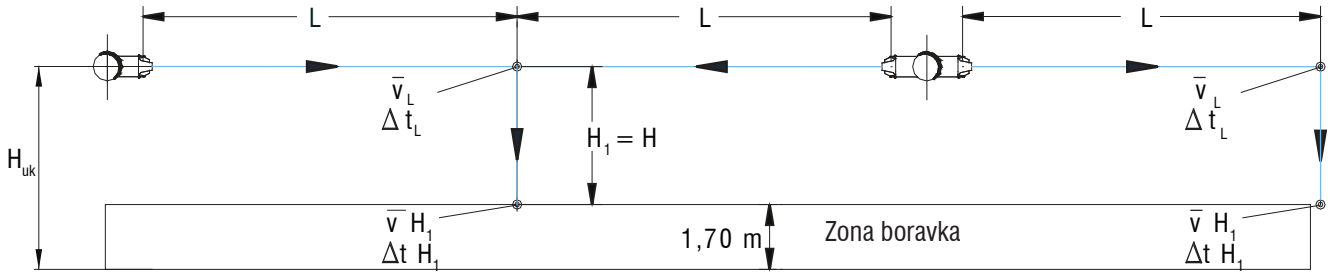
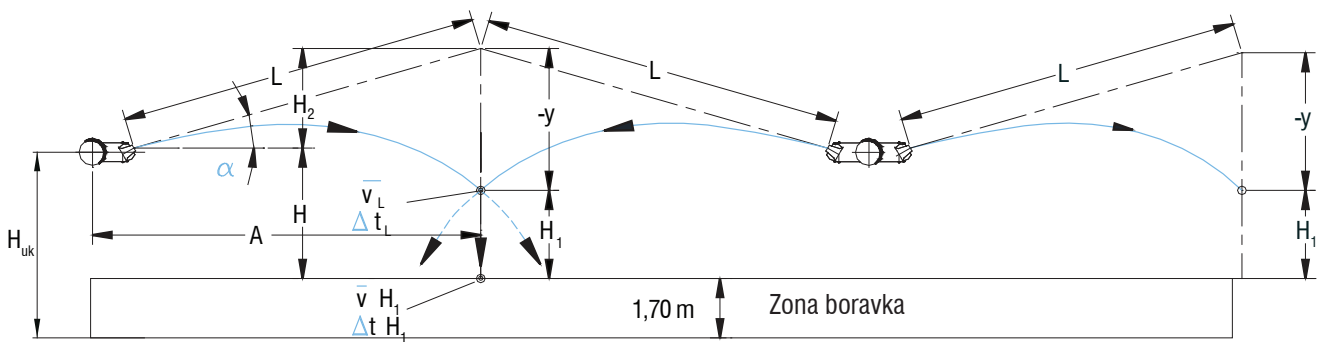
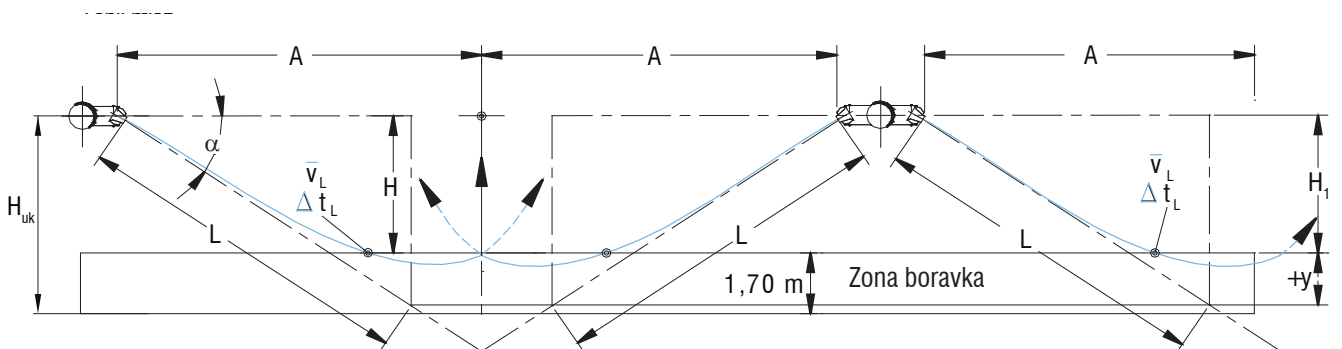
Izotermni mlaz

Hladni mlaz

Topli mlaz

SAPNICE

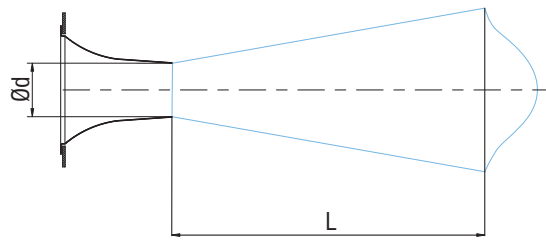
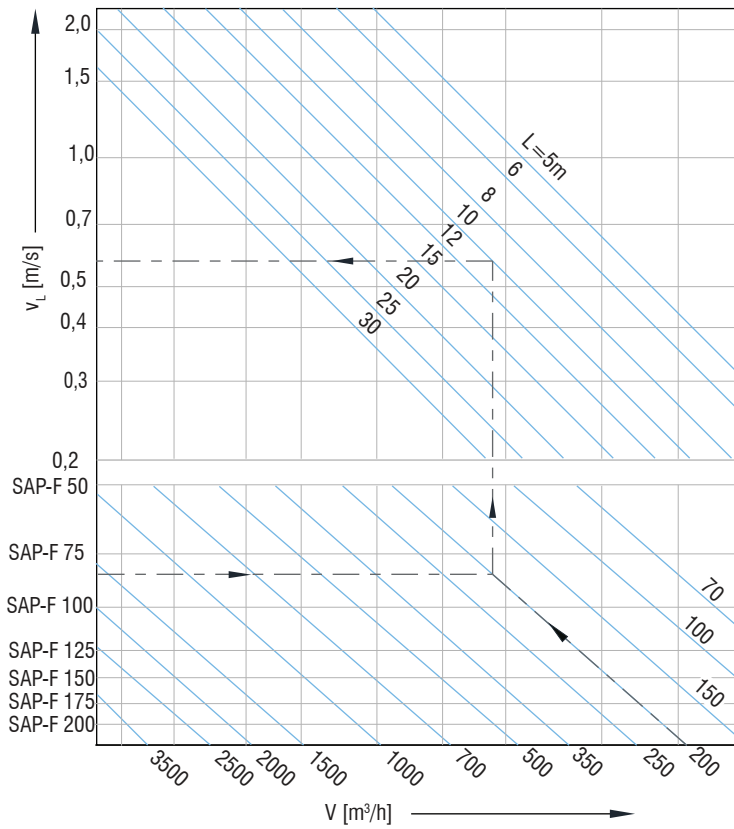
IZBORNI DIJAGRAMI

Horizontalni izotermni mlaz SAP-F



Horizontalni izotermni mlaz SAP-Z

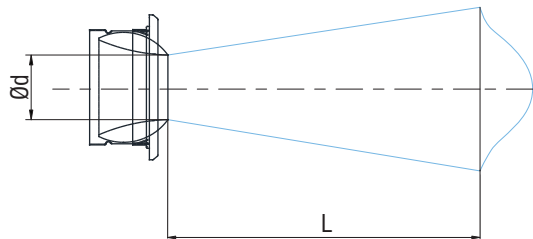
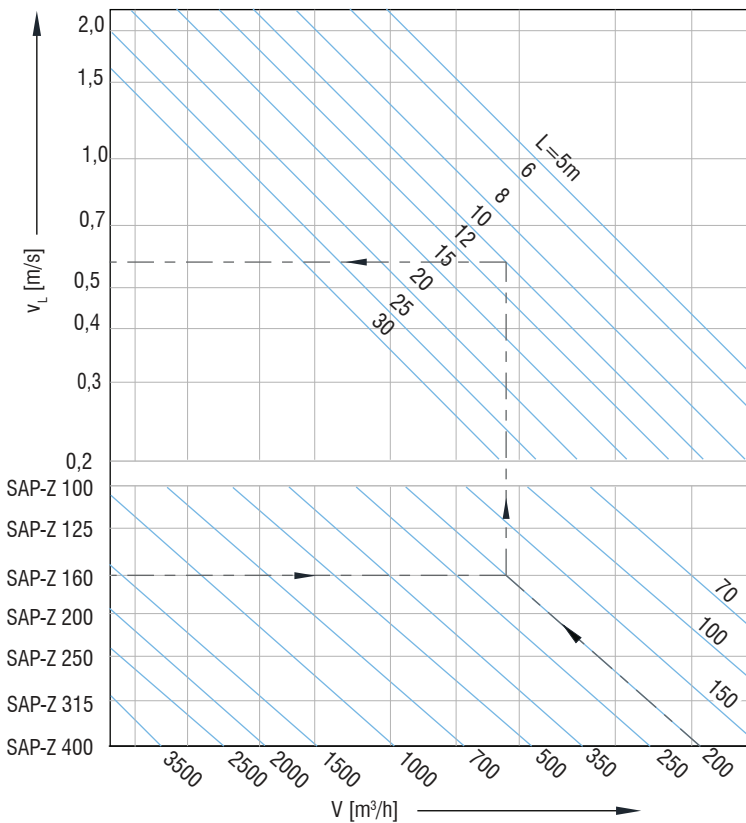

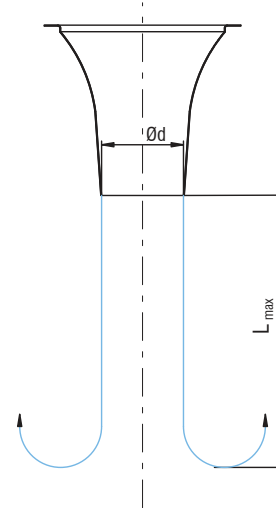
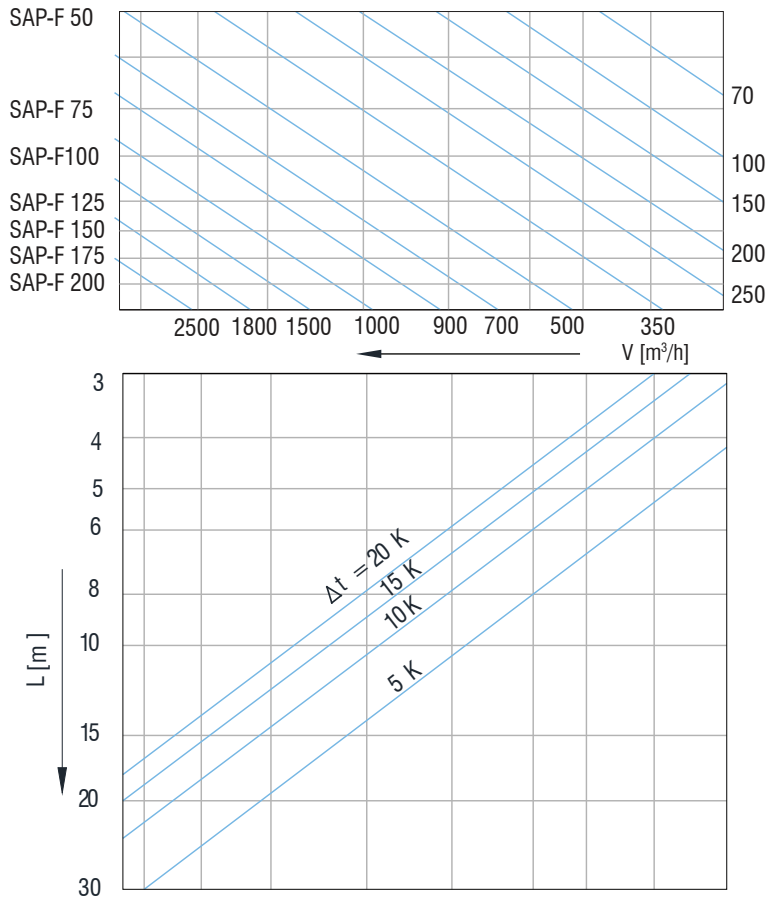
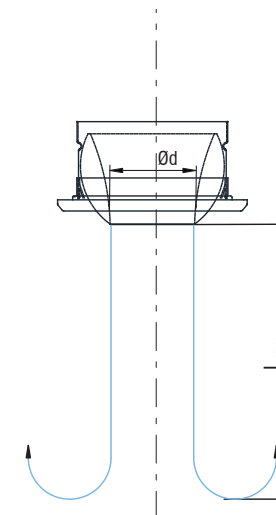
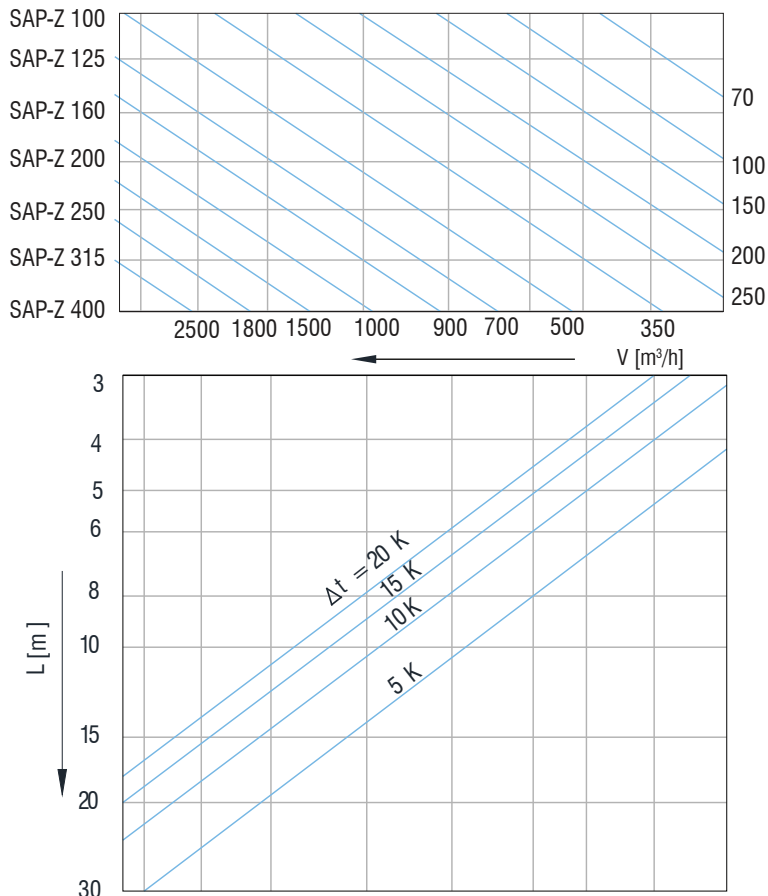
Vertikalni topli mlaz SAP-F

Vertikalni topli mlaz SAP-Z

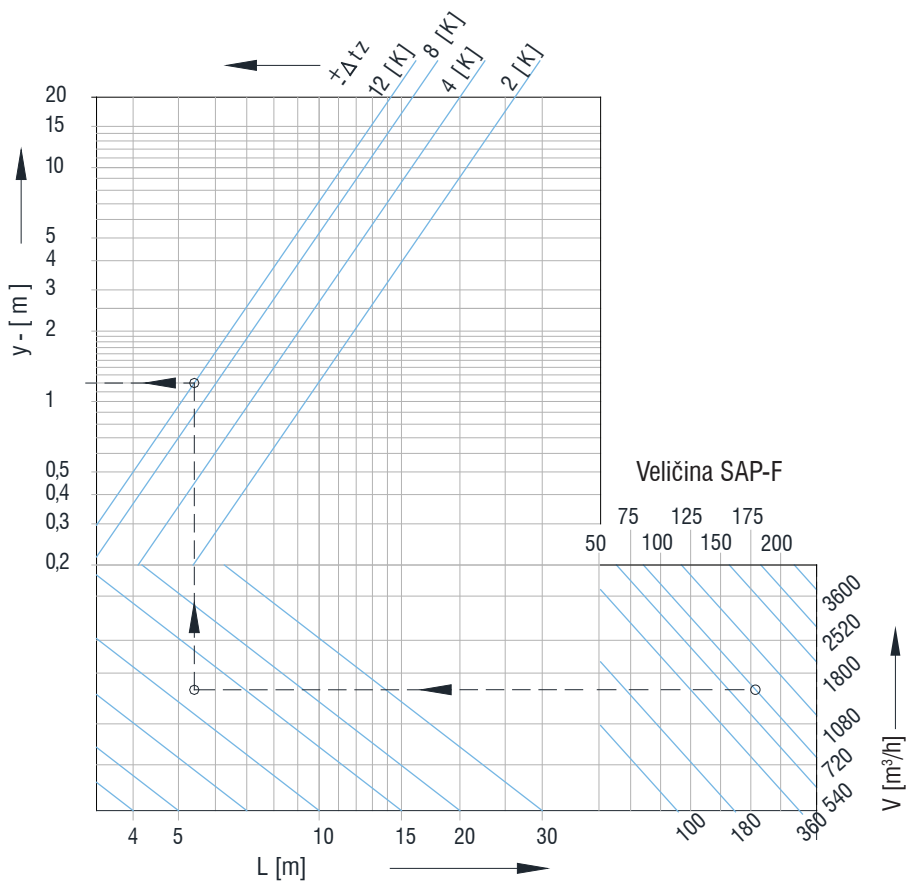
Otklon horizontalnog neizoternnog mlaza SAP-F

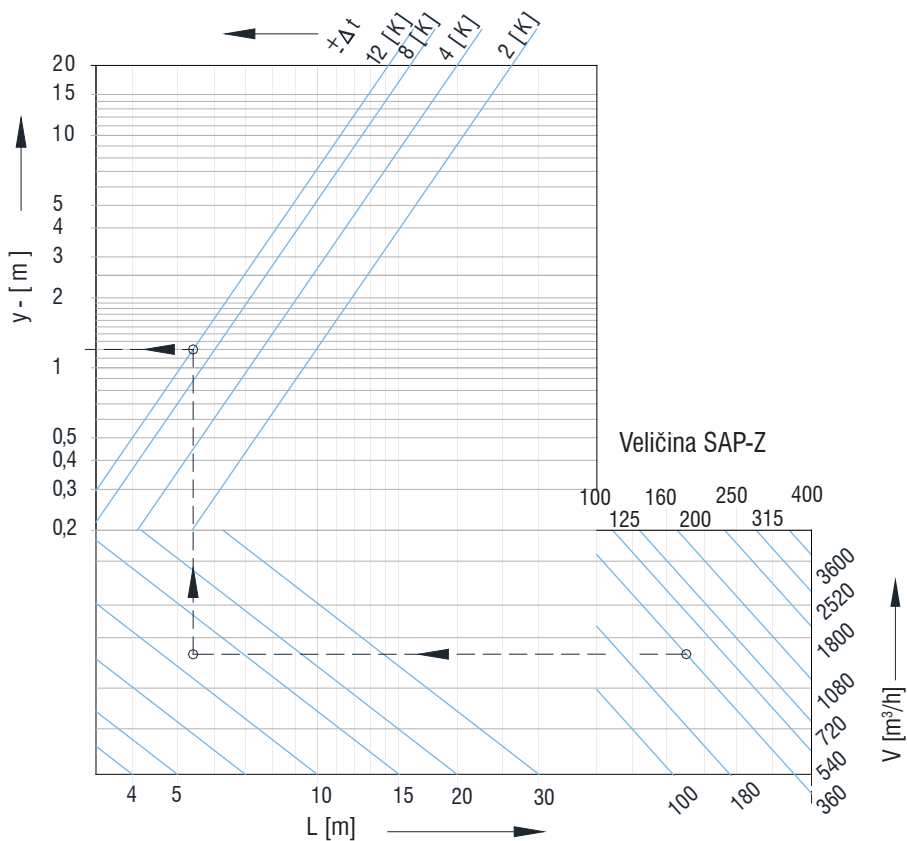

Otklon horizontalnog neizoternnog mlaza SAP-Z



Aksijalna ugradnja SAP-F

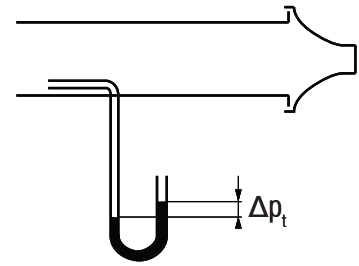
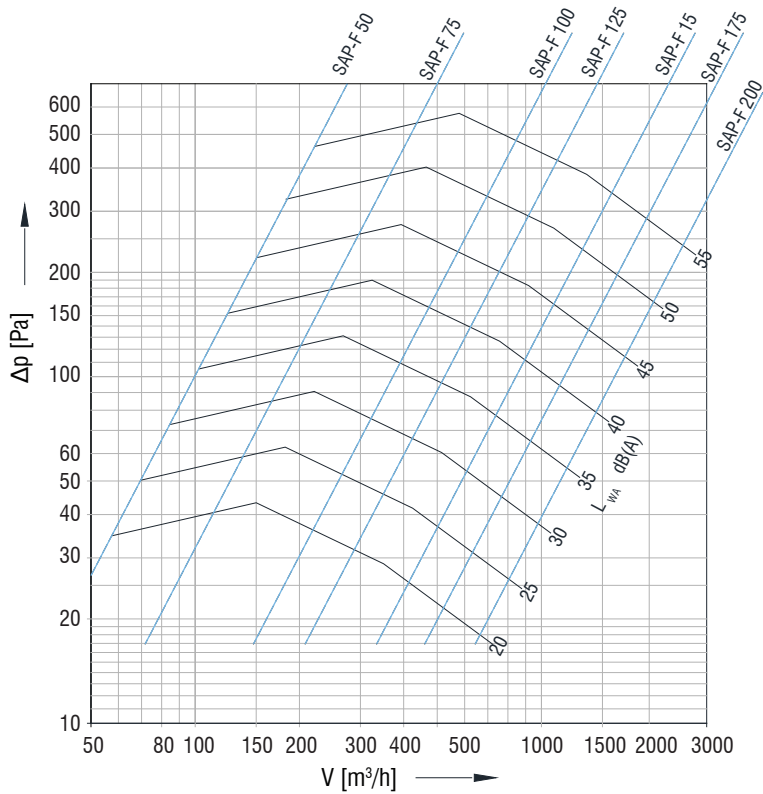

Aksijalna ugradnja SAP-Z

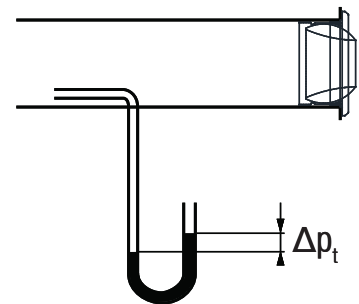
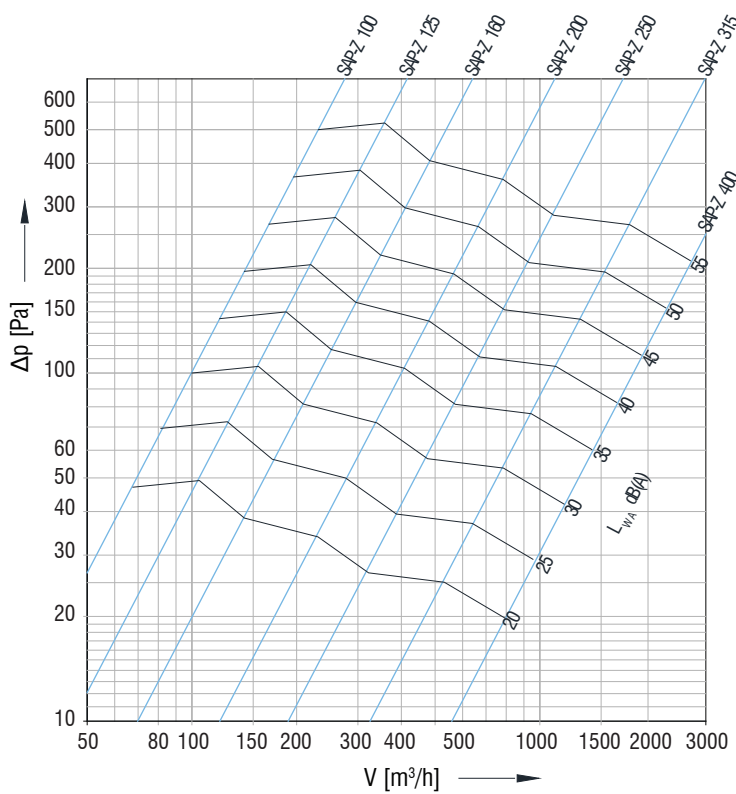

SAPNICE

Zajednička ugradnja na kanal SAP-F

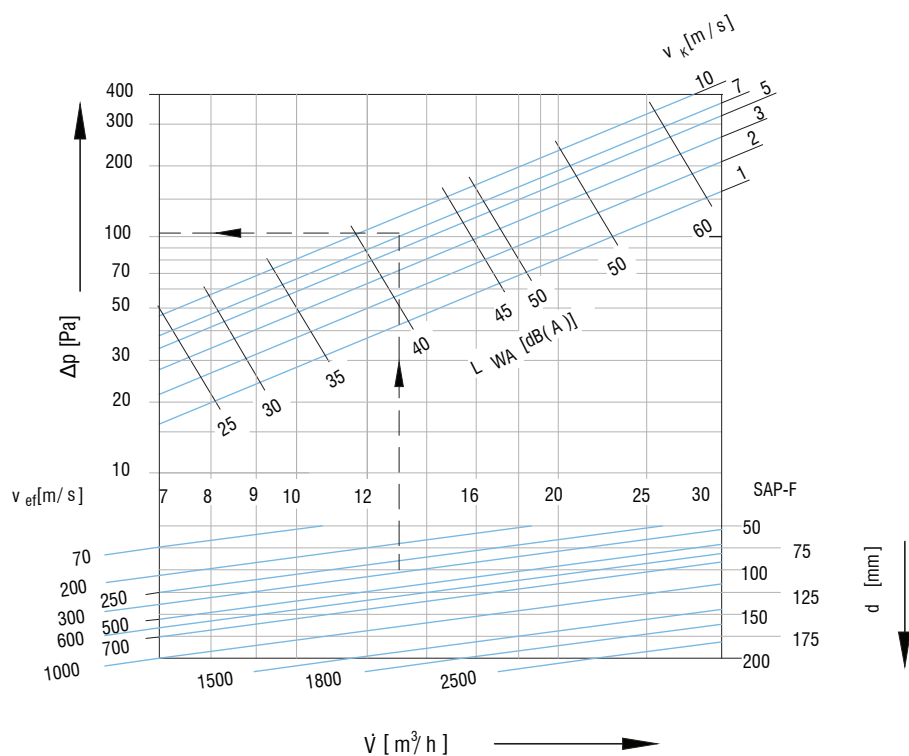

Zajednička ugradnja na kanal SAP-Z

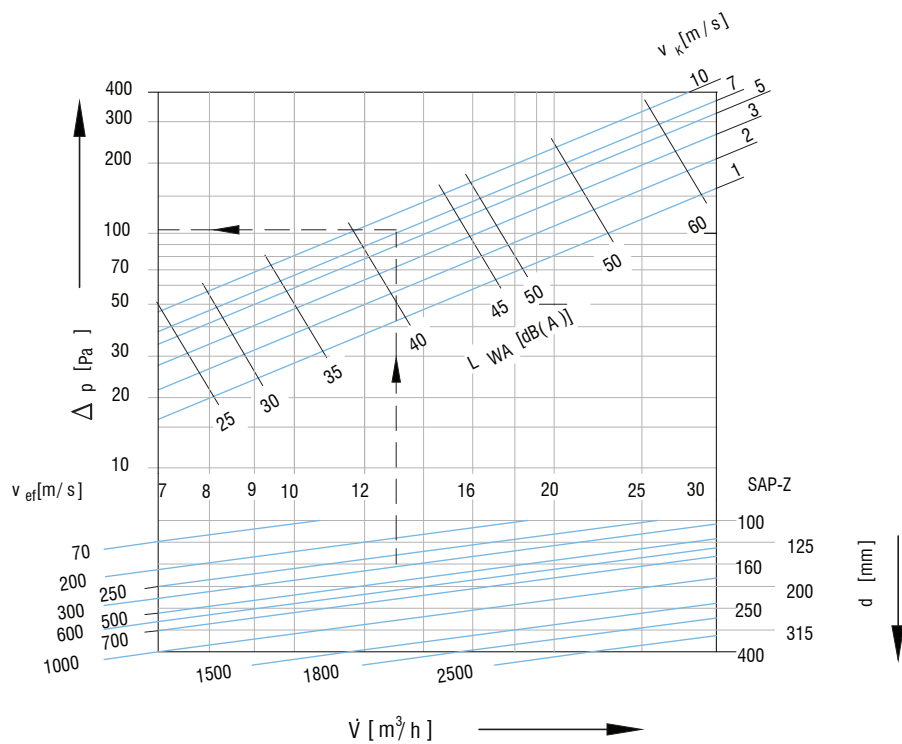

Za sapnice SAP-Z se kod kuta nagiba $+30^\circ$ pad tlaka uvećava za faktor $\times 1,2$

Korekcije vrijednosti L_{WA} [dB(A)]

σd	Kut namještanja	
	$\alpha = 0^\circ$	$\alpha = 30^\circ$
50	-6	-5
75	-3	-2
100	-2	0
125	1	2
150	3	4
175	4	6
200	5	7

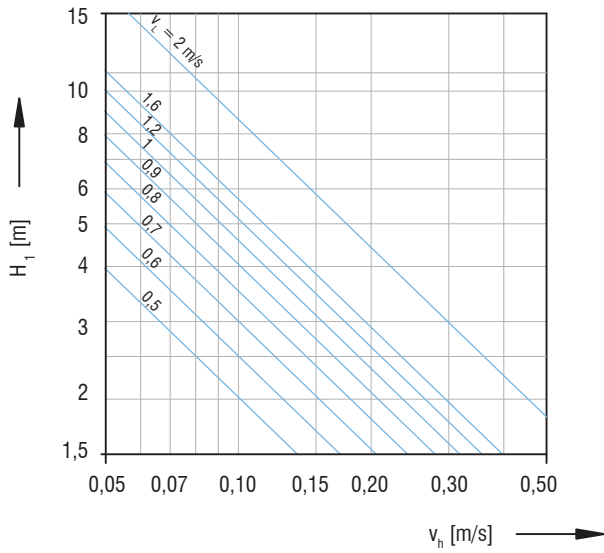
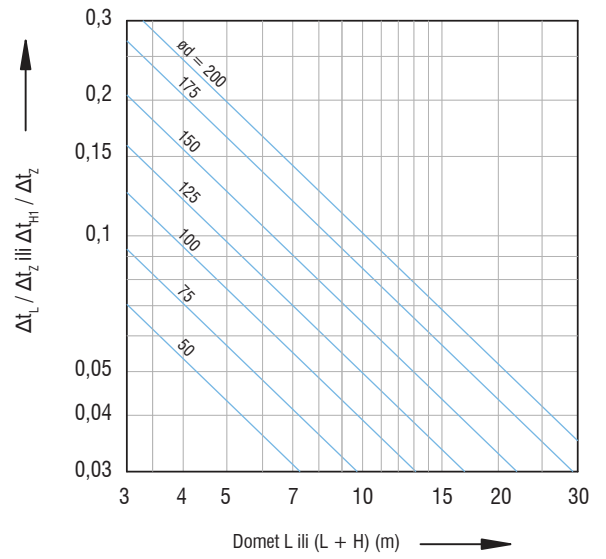
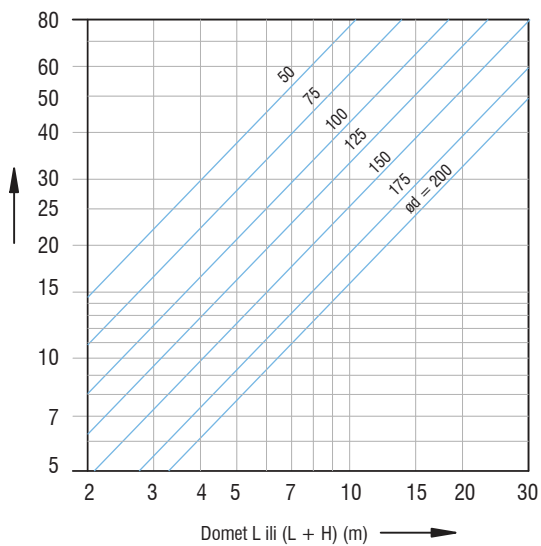
Srednja brzina na dometu

Temperaturni kvocijent

Indukcija

SAPNICE

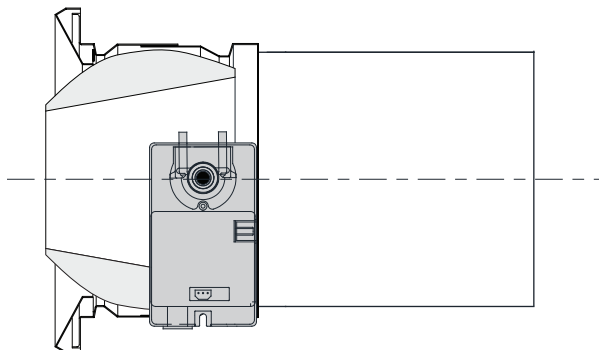
MOTORNI POGON

Standardna izvedba - motor na sapnici



Oznaka za narudžbu

Sapnica **SAP - Z - 400 - M230 - 1 - LO - RAL..**

Z - zglobna

F - fiksna

(SAP-F - odnosi se na izlazni promjer)

(SAP-Z - odnosi se na ulazni promjer)

* **M230-OZ** - motorni pogon, dvije pozicije

* **M230-K** - motorni pogon 230V, kontinuirani

* **M24-OZ** - motorni pogon 24V, dvije pozicije

* **M24-K** - motorni pogon 24V, kontinuirani

1 - vstandardna ugradnja motora

2 - specijalna ugradnja (izdvojeni pogon)

LO - leptirasta okrugla zaklopka

* Veličine 100 i 125 samo uz ručni pogon